

FACTORS THAT CONTRIBUTE TO THE WORK-FAMILY CONFLICT IN PERMODALAN NASIONAL BERHAD (PNB)

¹Assoc. Prof Dr Azizi Yahaya, ²Dr. Peter Voo, ³Assoc. Prof Dr Balan Rathakrishnan, ⁴Dr Ismail Maakip, ⁵Assoc. Prof Dr Baharudin Mohd. Arus, ⁶Dr Malai Yunus Malai Yusuf, ⁷Sonny anak Jumbo, ⁸Nor Hasnul Hamdani, ⁹Suraya Fadilah Ramli, ¹⁰Koay Ting Yin, ¹¹Nurul Diyana Mohamed Noor

¹Faculty of Psychology and Education, Universiti Malaysia Sabah MALAYSIA
profazizi_yahaya@yahoo.com

²Faculty of Psychology and Education, Universiti Malaysia Sabah, MALAYSIA peter@ums.edu.my

³Faculty of Psychology and Education, Universiti Malaysia Sabah, MALAYSIA
rbhalan@ums.edu.my

⁴Faculty of Psychology and Education, Universiti Malaysia Sabah,
MALAYSIA, daeng@ums.edu.my

⁵Faculty of Humanities, Art and Heritage Universiti Malaysia Sabah

⁶Universiti Teknologi Brunei, BRUNEI DARUSSALAM, dryunus.yusof@utb.edu.bn

⁷International Graduate Studies, BRUNEI DARUSSALAM, sonny@igsbrunei.edu.bn

⁸International Graduate Studies, BRUNEI DARUSSALAM, hasnulhamdani@gmail.com

⁹Center of Acturial Studies, UITM, MALAYSIA surayaramli@tmsk.edu.my

¹⁰Faculty of Psychology and Education, Universiti Malaysia Sabah, MALAYSIA,
bp17110210@student.ums.edu.my

¹¹Faculty of Business Management Universiti Teknologi Mara, Melaka

Abstract

Work–family conflict is a type of inter-role conflict that occurs as a result of incompatible role pressures from the work and family domains. Work role characteristics that are associated with work demands refer to pressure arising from excessive workload and time pressures. The purpose of this research is to identify the factors that contribute to the work-family conflict. There are three factors that researchers focus which are role overload, management support and also gender role orientation. The results of the study implied that work-family conflict as an important concern for individuals and organizations because of its negative consequences leading to reduced job performance as well as family satisfaction and hence reduced life satisfaction.

Keywords: Work-Family Conflict, Role Overload, Management Support, Gender Role Orientation

INTRODUCTION

As stated by the Greenhaus and Beutell (1985), work-family conflict is defined as “a form of inter-role conflict in which the role pressures from the work and family domains are mutually incompatible in some respect. Simply knowing that work–family conflict has a negative relationship with well-being does not enlighten one much, because the links among work, family and well-being are complex. As we know, employees today are more likely than ever concerned with how to balance their work and family lives. Competing demands, which arise between work and personal roles, often result in conflict for employees. There is a growing body of

research that reveals that work-family conflict is more prevalent than family-work conflict (Warner, 2005). Therefore, it is critical for employers to become aware of practices that can be implemented in order to reduce employees' work-family conflicts. The work of Decker and Borgen (1993) and Parasuraman, Zeithaml and Berry (1993) proclaimed the view that work-family conflict is closely associated with overall life stress. Meanwhile, Gornick and Meyers (2003) stated that work-family conflict has a potentially detrimental impact on personal effectiveness, marital relations, child-parent relationships and even child development.

For some time, work-family conflict has been shown to be negatively related to employee work outcomes such as absenteeism and turnover (Bowen, 1978; Galinsky & Stein, 1990). As early as 1981, Orpen reported that flexitime was related positively to job satisfaction. These findings were supported by other studies. Rothausen (1994), for example, reported work schedule flexibility to be negatively related to intention to quit (Aryee, Luk, Leung, & Lo, 1998), while Scandura and Lankau (1997) found that flexible work hour is related to higher organizational commitment.

Therefore, taking these cultural realities into account, this research adopted from Aminah Ahmad (2008), job, family and individual factors as predictors of work-family conflict. While this research examines on the factors that contribute to the work-family conflict, the focus will be on what can be realistically expected.

BACKGROUND OF COMPANY

If any thought could be burnt into the minds of every patriotic Malaysian, it should be this one, by a great Asian leader. And if there could be an event that sparked the transformation of the Malaysian economy, it would undoubtedly be the day Permodalan Nasional Berhad (PNB) was created. Incorporated on March 17, 1978, PNB was conceived as a pivotal instrument of the Government's New Economy Policy (NEP) to promote share ownership in the corporate sector among the Bumiputera, and develop opportunities for suitable Bumiputera professional to participate in the creation and management of wealth.

Prior to the establishment of PNB, efforts to increase Bumiputera ownership in the corporate sector were not sufficient as shares allocated to individuals were seldom retained. Research indicated that when Bumiputera shareholders sold their shares, the profit generated were consumed and not reinvested. Through PNB, substantial shares acquired in major Malaysian corporations from funds provided by Yayasan Pelaburan Bumiputera or Bumiputera Investment Foundation were transferred to a trust fund and sold to the Bumiputera in the form of smaller unit.

By employing the innovative investment model, PNB ensures that these shares are retained, resulting in the cultivation of widespread savings habit, and development of entrepreneurship and investment skills of Bumiputera. With fund under management, it sum up to about RM150 billion, the PNB Group is the country's leading investment institution with a diversified portfolio of interests that include unit trusts, institution property trust, property management and asset management.

Changes in the workplace and demography of employees had made the of relationship between work and family more important. Empirical evidence also confirms that work-family conflict is often a severe stress factor at work leading to various negative outcomes, including impaired well-being (Karatepe & Tekinkus, 2006). Acknowledging the prevalence of work family conflict and its negative outcomes, therefore, it is critical to develop a model on predictors of work-family conflict. This study explores the constraints and difficulties faced by PNB staffs that are pursuing their responsibility from the work and family. As stated by Pn. Norleala Bt Bahari, that "I got a lot of work to do. It is not only my routine job, but I also need to do my boss job when she is away" and En. Hussain said that "I can do my job efficiently if my boss explains well how to accomplish the task that had given to me", and other grievances such as not getting enough support from their supervisor or management had become the main conversation among them.

PNB is one of distinguished company in Malaysia and it is interesting to note that if the organization can discover the crisis faced by their employee such as the factors that contribute to the work-family conflict and at the same time come out with possible solution, hence their employees can perform their job well. Therefore, there is a need for PNB to investigate further into these variables by means of a well-designed survey.

RESEARCH QUESTIONS

Are there any impact between the factors of role overload, management support, gender role orientation towards work-family conflict?

HYPOTHESIS

Having hypothesis is to test whether the relationships that have been theorized which in fact hold true and

the researcher is able to obtain reliable information on what kinds of relationships exist among the variables operating in the problem situation. The null hypothesis (H_0) is expressed as no relationship between the variables, meanwhile alternative hypothesis (H_1) expressing a relationship between the variables.

Hypothesis 1

There is no significant impact between the factors of role overload, management support, gender role orientation towards work-family conflict

THEORETICAL FRAMEWORK

In this section, a theoretical framework for the factors that contribute to the work-family conflict among employees in PNB was developed based on the objectives and previous literature survey. This research will provide further insight as to what extend can the three independent variables influence in the work-family conflict among the employees.

Figure 1: Theoretical Framework

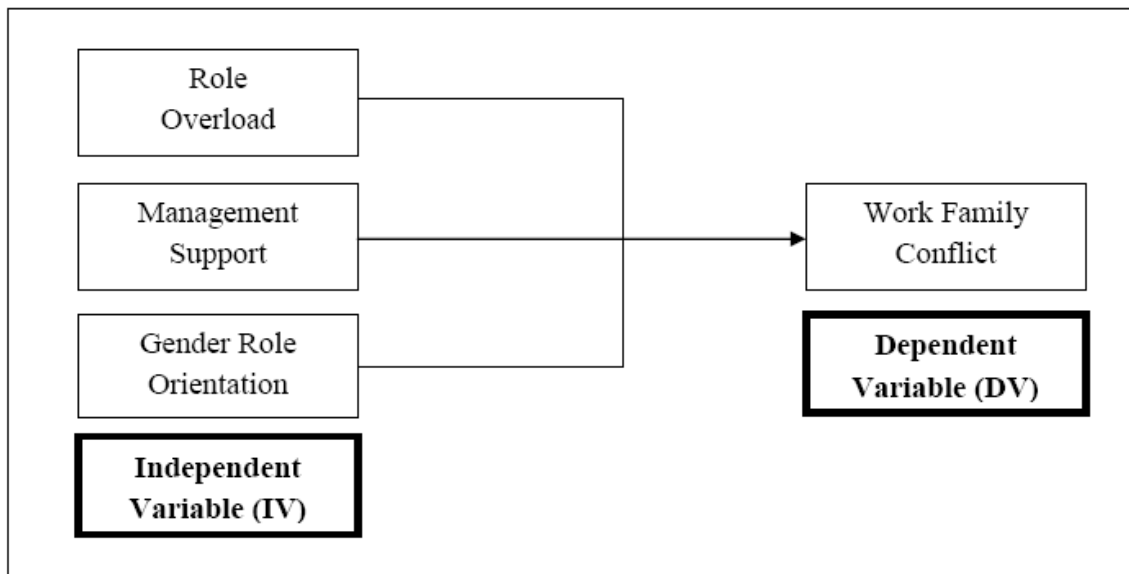

Sources: Adapted from Aminah Ahmad. Job, Family and Individual Factors as Predictors of Work-Family Conflict (2008)

The theoretical framework including the study variables is presented in Figure 1. It is expected that factors of role overload, management support and gender role orientation are associated with work-family conflict. Outcomes of work-family conflict include lower quality of work life and family life (Duxbury & Higgins, 1991), depression (Gutek, Searle, & Klepa, 1991). For the organization, the problems often associated with work-family conflict are absenteeism, tardiness, demoralization, and lower productivity in general (Ernst Kossek & Ozeki, 1998; Thomas, 1995). From this review, we can understand what if the staffs of PNB encounter the same issues in their workplace.

LITERATURE REVIEW

Work Family Conflict

Work-family conflict is a type of inter-role conflict in which the role demands stemming from one domain (work or family) which is incompatible with role demands stemming from another domain (family or work) (Greenhaus & Beutell, 1985; Kahn, Wolfe, Quinn, Snoek, & Rosenthal, 1964). Work-family conflict is often the result of having too many things to do and too little time in which to accomplish them (Greenhaus & Beutell, 1985; Voydanoff, 2002) since work schedules tend to be less flexible than personal schedules (Eagle, Miles, & Icenogle, 1997). The assumption that work and family are separate spheres and in competition for resources such as time and attention continues to be dominant in our society (Barnett, 1998). People should know that work-family conflict (WFC) addresses the impact which can ruin the family. Family-work conflict (FWC) addresses the impact of the family on the work activities of the family member.

The problem of work-family conflict (WFC) has been studied extensively in the literature, which is dominated by research conducted mainly on white-collar managerial and non-managerial employees working in private

sector organizations (Eby, Casper, Lockwood, Bordeaux, & Brinley, 2002). The majority of research on work–family conflict has been conducted in Western industrialized societies, but there is an increasing recognition of the role of culture in work–family conflict (Aryee et al., 1999; Aycan, 2008). WFC is related to negative psychological and organizational outcomes, such as increase in depressive symptoms, increase in the use of alcohol and substance abuse, decrease in life satisfaction, job satisfaction and marital satisfaction, and increase in the tendency to quit the job (Eby et al., 2002). However, not everyone with heavy work demands experiences WFC to the same extent. Similarly, those experiencing work-family conflict are not guaranteed to suffer from lower life and job satisfaction.

METHODOLOGY

The study is to elicit information on the factors that contribute to the work family conflict to the employee of PNB. The study is purely a descriptive study where variables in this study had already occurred and are not subject to manipulations. Role overload, management support and gender role orientation are the independent variables while work-family conflict is the dependent variable. The goal of a descriptive study is to offer to the researcher a profile or to describe relevant aspects of the phenomena of interest from an individual and also the company itself (Sekaran, 2003). Descriptive study that present data in a meaningful form thus help to understand the characteristics of a group in a given situation, think systematically about aspects in a given situation, offers ideas for further probe and research and also help make certain simple decision. Whereas qualitative data obtained by distributing questionnaires to the staff of PNB may help the understanding of phenomena at the exploratory stages of a study, quantitative data in terms of the frequencies, or mean and standard deviation, become necessary for descriptive study.

Types Of Study

The researcher used causal versus correlation study to establish a definitive cause and effect relationship (Sekaran, 2003). The researcher is keen on conducted a causal study which able to state that independent variables which are role overload, management support and gender role orientation causes the work-family conflict.

Population

Population (n) refers to the entire group of people, events, or things of interest that the researcher wishes to investigate (Sekaran, 2003). In this research, the participants in this study was drawn from the staffs at PNB, Kuala Lumpur and there are different staff grade level from clerk to the executive level. Permodalan Nasional Berhad (PNB) has 340 employees and it is consist of 57 departments and out of 9 departments was randomly selected for the study. Meanwhile, sample can be defined as a subset of the population. A convenience sample for this research is 180 employees.

Sampling Method

There are two types of sampling design which is probability and non-probability sampling. In probability sampling, the elements in the population have some known chance or probability of being selected as sample subjects. Meanwhile, non-probability sampling the elements to do not have a known or predetermined chance of being selected as subjects (Sekaran 2003) Probability sampling means the elements in the population have some known chance or probability of being selected as sample subject (Sekaran, 2003). In this research, the researcher will use simple random sampling (SRS) or unrestricted because every element in the population has an equal chance of being selected as subject. The advantages of using simple random sampling are it has least bias and offers the most generalizability.

RESULT

This section explained about the analysis that was done by the researcher with several tests and analysis. The process of analysis begins after the data had been collected. The objectives of data analysis are to test the goodness of data and the hypothesis developed for the research. During this stage, several interrelated procedures were performed to summarize and rearrange the data. The result had been analyzed by using two methods, which are qualitative method which used descriptive explanation and quantitative method which is more on statistical explanation by using correlation analysis and regression analysis test.

Correlation between the factors of role overload, management support, gender role orientation and work-family conflict

Table 1: Pearson Correlation between the factors of role overload, management support, gender role orientation and work-family conflict. (N = 180)

There is no significant relationship with work-family conflict	Pearson Correlation (r)	Significant Value	Result
Role Overload	.049	.510	Accepted
Management Support	-.368**	.000	Rejected
Gender Role Orientation	-.368**	.000	Rejected

Note: *p < .05, **p < .01, ***p < .001, 2-tailed

Table 1 indicates the Pearson correlation analysis which were measured between the factor of role overload, management support, gender role orientation and work-family conflict. Finding shown that there was a positive not significant relationship between role overload factor and work-family conflict ($r = .049$, $p > .05$). However, there was a negative significant relationship between management support factor and work-family conflict ($r = -.368$, $p < .01$). This implied that the higher the management support, the lower the work-family conflict experienced by the respondents. In addition, there was also a negative significant relationship between gender role orientation factor and work-family conflict ($r = -.368$, $p < .01$). The findings implied that the stronger the gender role orientation, the lower the work-family conflict experienced by the respondents.

Table 2: Coefficient

	Modal	Unstandardized Coefficient		Standardized Coefficient	T	Sig.
		B	Std. Error	Beta		
1	(Constant)	3.980	.452		8.814	.000
	Role Overload	.124	.099	.088	1.255	.211
	Gender Role Orientation	-.418	.077	-.368	-5.397	.000
2	(Constant)	4.394	.308		14.253	.000
	Gender Role Orientation	-.408	.077	-.368	-5.288	.000

From the above table, it shows that the most influential factors that contribute to the work-family conflict which is the dependent variable in this research. Based on the Beta under standardized coefficient, it shows the highest number in the beta is $-.368$ for gender role orientation, which is significant at the .000 level. So, it means that, gender role orientation is the most influential factor that contributes to the work-family conflict of the PNB staff.

CONCLUSION AND RECOMMENDATION

Conclusion

As a conclusion, the researcher found that there are many factors that contribute to the work-family conflict and the researcher also had achieved the entire objective stated. The researcher also had identified four objectives that to be achieved. First objective is to identify the most influential factors that contribute to the work-family conflict to the PNB personel. The second objective is to identify the significant correlation between role overload and work-family conflict. Third is to identify the significant correlation between management support and work-family conflict and lastly to identify the significant correlation between gender role orientation and work-family conflict among employees at PNB.

First objective stated that to identify the most influential factors that contribute to the work-family conflict, it indicates that the most influential factor that contributes to the work-family conflict at PNB is gender role

orientation. Second objective is to identify the significant correlation between role overload and work-family conflict also attained. It shows in the table 1, where it indicates there is no significant correlation relationship between roles overload and work family conflict among employees at PNB ($r = .049$). Therefore, there is no significant relationship between the variables.

Third objective is to identify the significant correlation relationship between management support and work-family conflict also completed. It shows in the table 1, where it indicates there is a significant correlation between management support and work-family conflict among employees at PNB ($r = -.368$). It means that, if management supports increase, the work-family conflict will decrease and vice versa. Based on the rules of thumbs for correlation relationship, it shows moderate negative relationship.

Last objective is to identify the significant correlation relationship between gender role orientation and work-family conflict also accomplished. It shows in the table 1, where it indicates there is a significant correlation relationship between gender role orientation and work-family conflict among employees at PNB ($r = -.368$). It also means when conflict in gender role orientation increase, work-family conflict will decrease or vice versa. Based on the rules of thumbs for correlation relationship, it shows moderate negative relationship.

REFERENCE LIST

- A. Ahmad. (2008). Job, Family and Individual Factors as Predictors of Work-Family Conflict. *The Journal of Human Resource and Adult Learning*. 4(1), 59-60.
- A. Ahmad, & M. Baba. (2003). The effects of role overload and social support on work-family conflict. *The Journal of Asian Regional Association of Home Economics*. 10(4), 196-201.
- Aryee, S., Luk, V., Leung, A., & Lo, S. (1999). Role stressors, interrole conflict, and well-being: The moderating influence of spousal support and coping behaviours among employed parents in Hong Kong. *Journal of Vocational Behaviour*. 54(4), 259-278.
- Aycan, Z. (2008). Cross-cultural perspectives to work-family conflict. In K. Korabik & D. Lezro (Eds.), *Handbook of Work-Family conflict*, 359-371. London: Cambridge University Press.
- Barnett, J. (1998). In defence of the nation-state: securing the environment. *Sustainable Development*, 6(1), 8–17. doi:10.1002/(sici)1099-1719(199803)6:1<8::aid-sd81>3.0.co;2-u
- Barnett, R. C., & Hyde, J. S. (2001). Women, men, work, and family: An expansionist theory. *American Psychologist*, 56(10), 781–796. doi:10.1037/0003-066x.56.10.781
- Bhagwagar, H. (2009). *Need for workplace counseling in India*. Retrieved from <http://prod.bolohealth.com/healthzones/21-total-health/article/165-needfor-workplace-counseling-in-india>.
- Bowen, M. (1978). *Family Therapy in Clinical Practice*. NY and London, Jason Aronson.
- Burke, R. J., & Greenglass, E. R. (1999). Work–family conflict, spouse support, and nursing staff well-being during organizational restructuring. *Journal of Occupational Health Psychology*, 4(4), 327–336. doi:10.1037/1076-8998.4.4.327
- Cobb, S. (1976). Social Support as a Moderator of Life Stress. *Psychosomatic Medicine*. 38(5), 300-314.
- Connell, R. W. (2005). Globalization, imperialism, and masculinities. In M. S. Kimmel, J. Hearn, & R. W. Connell, *Handbook of studies on men & masculinities*. Thousand

Oaks, CA: Sage.

Decker, P. J., & Borgen, F. H. (1993). Dimensions of work appraisal: Stress, strain, coping, job satisfaction, and negative affectively. *Journal of Counselling Psychology*, 40(4), 470-478. doi: 10.1037/0022-0167.40.4.470

Duxbury, L. E., & Higgins, C. A. (1991). Gender differences in work-family conflict. *Journal of Applied Psychology*, 76(1), 60–74. doi:10.1037/0021-9010.76.1.60

Greenhaus, J. H., & Powell, G. N. (2003). When Work and Family Collide: Deciding between Competing Role Demands. *Organizational Behaviour and Human Decision Processes*, 90, 291-303. [http://dx.doi.org/10.1016/S0749-5978\(02\)00519-8](http://dx.doi.org/10.1016/S0749-5978(02)00519-8)

Gornick, J., & Meyers, M. (2003). Families That Work: Policies for Reconciling Parenthood and Employment. *Russell Sage Foundation*. Retrieved from <http://www.jstor.org/stable/10.7758/9781610442510>

Gunkel, M. (2007). Gender-specific effects at work: An empirical study of four countries. *Gender, Work and Organization*, 14(1), 56-79.

Gutek, B. A., Searle, S., & Klepa, L. (1991). Rational versus gender role explanations for work-family conflict. *Journal of Applied Psychology*, 76(4), 560-568. doi:10.1037/0021-9010.76.4.560

Scandura, T., & Lankau, M. J. (1997). Relationships of gender, family responsibility and flexible work hours to organizational commitment and job satisfaction. *Journal of Organizational Behavior*, 18(4), 377-391.

Sekaran, U. (2003). *Research Methods for Business: A Skill-Building Approach*. (4th ed.). John Wiley & Sons, New York.

Smithson, J., & Stokoe, E. H. (2005). Discourses of Work-Life Balance: Negotiating “Genderblind” Terms in Organizations. *Gender, Work and Organization*, 12(2), 147–168. doi:10.1111/j.1468-0432.2005.00267.x

Staines, L. G., & O'Connor, P. (1980). Conflicts among Work, Leisure, and Family Roles. *Monthly Labor Review*. 103.

Thomas, J. (1995). *Meaning in Interaction: An Introduction to Pragmatics*. London: Longman.

Thomas, L. T., & Ganster, D. C. (1995). Impact of family-supportive work variables on work-family conflict and strain: A control perspective. *Journal of Applied Psychology*, 80(1), 6–15. doi:10.1037/0021-9010.80.1.6

Valcour, M. & Hunter, L. W. (2004). *Technology, organizations, and work-life integration*.

Voydanoff, P. (2002). Linkages Between the Work-family Interface and Work, Family, and Individual Outcomes. *Journal of Family Issues*, 23(1), 138–164. doi:10.1177/0192513x02023001007

Warner, J. (2005). Labor in information systems. *Annual Review of Information Science and Technology*, 39(1), 551-573. doi: 10.1002/aris.1440390120

York, R. O., & Denton, R. T. (1990). Leadership behaviour and supervisory performance: The view from below. *The Clinical Supervisor*, 8(1), 93-108.